

Wiring Diagram

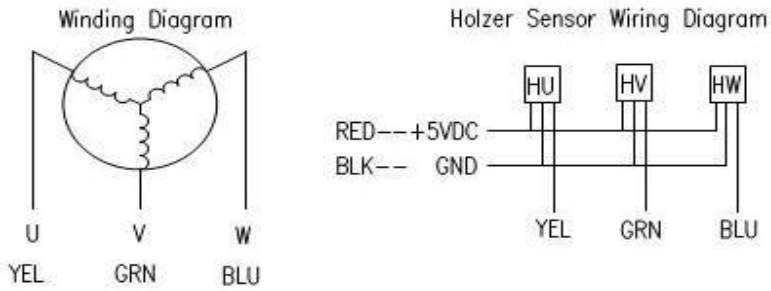

Appearance Size & Motor Installation

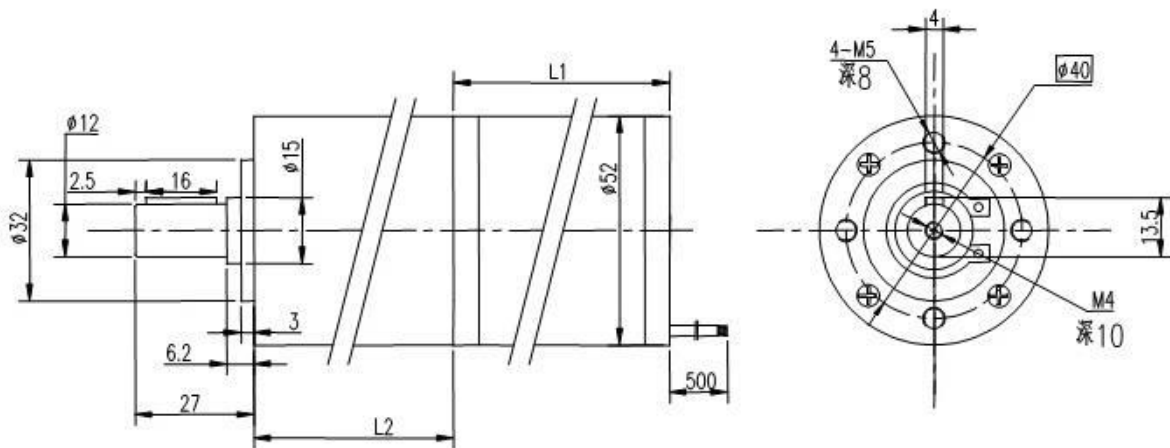

Motor Electrical Specification

Motor Model	DG525-31W	DG525-63W	DG525-94W
Rated Voltage(VDC)	24	24	24
Rated Speed(Rpm)	3000	3000	3000
Rated Torque(N.m)	0.1	0.2	0.3
Rated Power(W)	31	63	94
L1 Length(mm)	59	79	99

Gearbox Electrical Specification

Reducer Series	1	2
Transmission efficiency	90%	81%
Max radial load	200N	200N
Max axial load	100N	100N
Transmission torque	6N.m	12N.m
Reduction Ratio	5,10	20,25,40,50,100
L2 Length(mm)	35.5	45

* Note: We can manufacture products according to customer's requirements.
Optional accessory is the encoder and brake to match this product.

* Contact sales@ichmo.com.