

User Guide

HOLSEM-A2 LED DISPLAY

Specification & Feature:

- Voltage:120V~ 60Hz
- Wattage: 1500Watts
- Capacity of basket: 3.4 Quart
- Adjustable temperature:170°F—400°F
- Timer (0-60 min)

General description (Fig.1)

1. Control panel
2. Lid
3. Lid ornament
4. Main housing
5. Basket
6. Button cover
7. Basket release button
8. Basket handle
9. Air outlet openings
10. Power cord

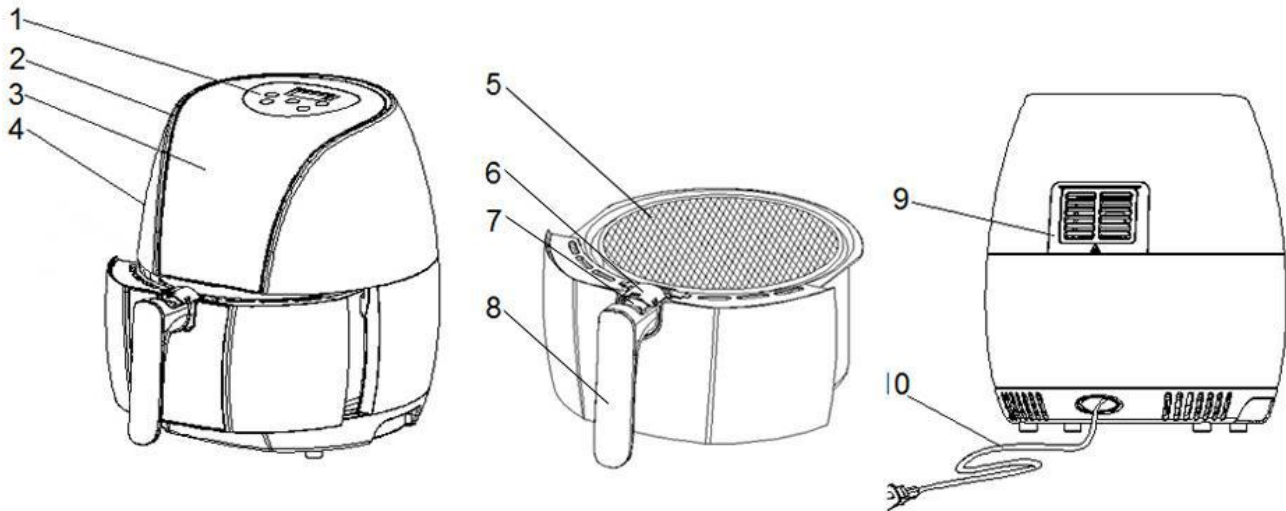

Fig.1

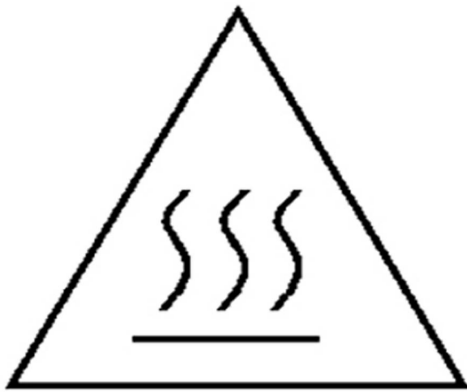

Fig.2

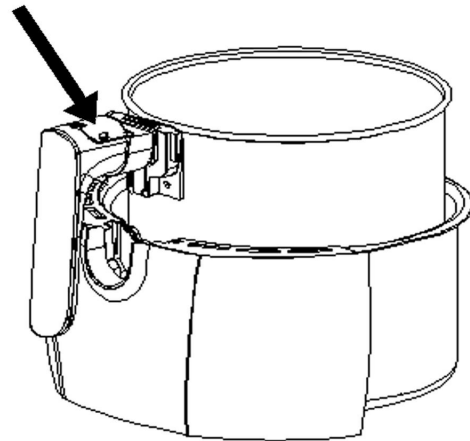

Fig.3

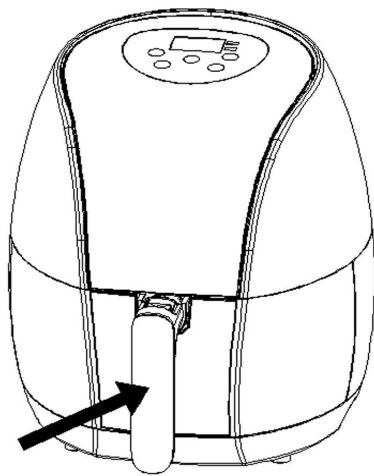

Fig.4

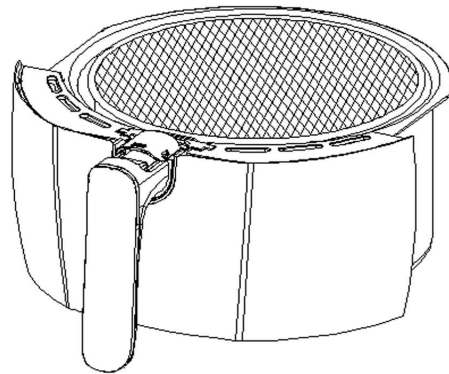

Fig.5

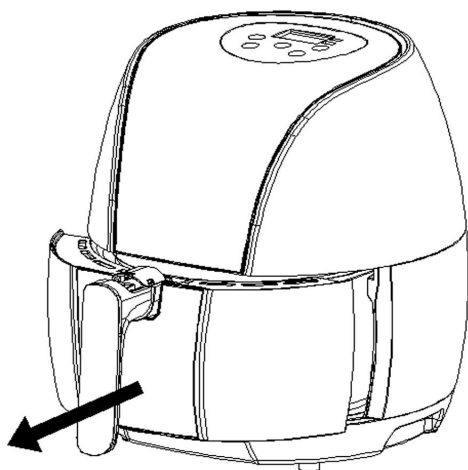
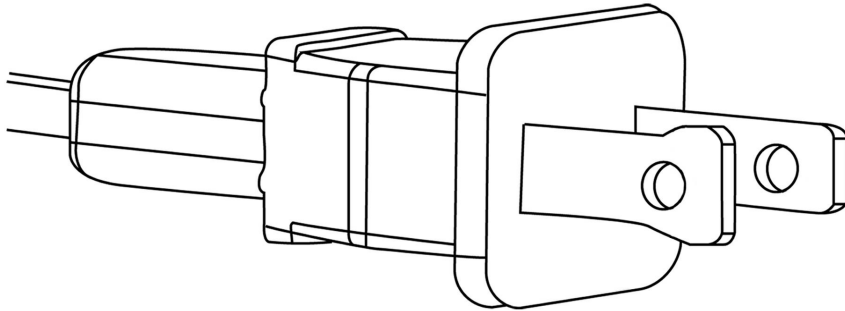

Fig.6

For indoor use only

This appliance is designed for indoor use only.

Polarized Plug



This appliance has a polarized plug (one blade is wider than the other). With the safety feature to reduce the risk of electrical shock, this plug is intended to fit in a polarized outlet only one way. If the plug does not fit fully in the outlet, reverse the plug. If it still does not fit, contact a qualified electrician. Do not attempt to defeat this safety feature or modify the plug in any way. If the plug fits loosely into the AC outlet or if the AC outlet feels warm, do not use that outlet.

Introduction

This air fryer provides an easy and healthy way of preparing your favorite ingredients. By using hot and rapid air circulation and a top grill, it is able to make numerous dishes. The best part is that the air fryer heats food at all directions and most of the ingredients do not need any oil.

Important

Please read this manual carefully before you use the appliance and save it for future reference.

Danger

- Never immerse the housing, which contains electrical components and the heating elements in water or rinsing under the tap.
- Avoid any liquid in the appliance to prevent electric shock or short circuit.
- Keep all ingredients in the basket and prevent any contact from heating elements.
- Do not cover the air outlet when the appliance is working.
- Filling the pan with oil may cause fire hazards.
- Don't touch the inside of the appliance while it is working.

Warning

- This appliance is not intended for use by persons (including children) with reduced physical, sensory or mental capabilities, or lack of experience and knowledge, unless they are under supervision or have been given instructions concerning use of the appliance by a person responsible for their safety.
- Check if the voltage indicated on the appliance fits the local mains voltage.
- Do not use the appliance if there is any damage on the plug, mains cord or other parts.
- Do not ask for any unauthorized person to replace or fix the damaged mains cord.
- Keep the mains cord away from hot surfaces.
- Do not plug in the appliance or operate the control panel with wet hands.
- Do not place the appliance against a wall or other appliances. Leave at least 10cm free space on each side and 10cm free space above the appliance.
- Do not place anything on top of the appliance.
- Do not use the appliance for any other purposes than described in this manual.
- Do not leave the appliance unattended in operation.
- During hot air frying, hot steam is released through the air outlet openings. Keep your hands and face at a safe distance from the steam and from the air outlet openings. Also be careful of hot steam and air when you pull out the pan from the appliance.
- Any accessible surfaces may become hot during use. (Fig.2)
- Immediately unplug the appliance if you see dark smoke coming out of the appliance. Wait for the smoke emission to stop before you pull out the pan from the appliance.

Caution

- Ensure the appliance is placed on a horizontal, even and stable surface.
- This appliance is designed for indoor or household use only. It may not be suitable to be safely used in environments such as staff canteens, farms, motels, and other non-residential environments. Nor is it intended to be used by clients in hotels, motels, bed and breakfasts and other residential environments.
- If the appliance is used improperly or for professional or semi-professional purposes or if it is not used according to the instructions in the user manual, the guarantee becomes invalid and we could refuse any liability for any damages caused.
- Always unplug the appliance when it is not used.
- The appliance needs approximately 30 minutes to cool down for handling or cleaning safely.

Automatic switch-off

This appliance is equipped with a timer. When the timer counts down to 0, the appliance clicks and switches off automatically. To switch off the appliance manually, press the button “⏻” for more than 3 seconds. (Fig.8)

Before first use

1. Remove all packaging materials.
2. Remove any stickers or labels from the appliance.
3. Thoroughly clean the basket and pan with hot water, some dish washing liquid and a non-abrasive sponge.

Note: You can also clean these parts in the dishwasher.

4. Wipe the inside and outside of the appliance with moist cloth.

5. This oil-free fryer works with hot air. Do not fill the pan with oil or frying fat.

Preparing for use

1. Place the appliance on a stable, horizontal and even surface.

Note: Do not place the appliance on a non-heat-resistant surface.

2. Place the basket in the pan. (Fig.3)

3. Pull out the cord from the storage compartment which is on the bottom of the appliance.

Note: Do not fill the pan with oil or any other liquid.

Do not put anything on top of the appliance, or the airflow will be disrupted and the hot air frying will be affected.

Using the appliance

The oil-free fryer can prepare a large range of ingredients. The recipe booklet can help you get to know the appliance.

Hot-air frying

1. Plug in the mains plug.

2. Carefully pull the pan out of the air fryer. (Fig.6)

3. Put the ingredients in the basket. (Fig.5)

Note: Do not exceed the MAX indicator (see section "settings" in this chapter), as it may affect the cooking quality of the food.

4. Slide the pan back into the air fryer. (Fig. 4)

Note: Never use the pan without the basket in it.

Do not touch the pan during and some time after use, as it gets very hot. Only hold the pan by the handle.

5. Determine the required preparation time for the ingredients (see section 'Settings' in this chapter).

Note: Add 3 minutes to the preparation time if the appliance is cold.

If you want, you can also let the appliance preheat without any ingredients inside. Then fill the basket and press the timer to the required preparation time.

6. The timer starts counting down the set preparation time.

Note: Excess oil from the ingredients is collected on the bottom of the pan.

7. Some ingredients require shaking halfway through the preparation time (see section "Settings" in this chapter). To shake the ingredients, pull the pan out of the appliance by the handle and shake it. Then slide the pan back into the fryer.

Tip: To reduce the weight, you can remove the basket from the pan and shake the basket only. To do so, pull the pan out of the appliance, place it on a heat-resistant surface and press the button on the handle and pull the basket out of the pan. (Fig.3)

Tip: If you set the timer to half of the preparation time, you hear the timer clicks when you have to shake the ingredients. However, this means that you have to set the timer again to the remaining preparation time after shaking.

8. When you hear the timer clicks, the set preparation time has elapsed. Pull the pan out of

the appliance and place it on a heat-resistant surface.

Note: You can also switch off the appliance manually. Press the “1” Power button for 3 seconds, and the unit turns off.

9. Check if the ingredients are ready. If the ingredients are not ready yet, simply slide the pan back into the appliance and set the timer to a few extra minutes.

10. To remove ingredients (e.g. fries), pull the pan out of the air fryer and place it on a heat-resistant surface, and press the basket release button and lift the basket out of the pan. (Fig.3)

Do not turn the basket upside down before pulling it out of the pan, as any excess oil that has been collected on the bottom of the pan will leak onto the ingredients.

Please note that the pan and the ingredients are hot. Depending on the type of the ingredients in the air fryer, steam may escape from the pan.

11. Empty the basket into a bowl or onto a plate.

Tip: To remove large or fragile ingredients, take the ingredients out of the basket by a pair of tongs.

12. When a batch of ingredients is ready, the air fryer is instantly ready for preparing another batch.

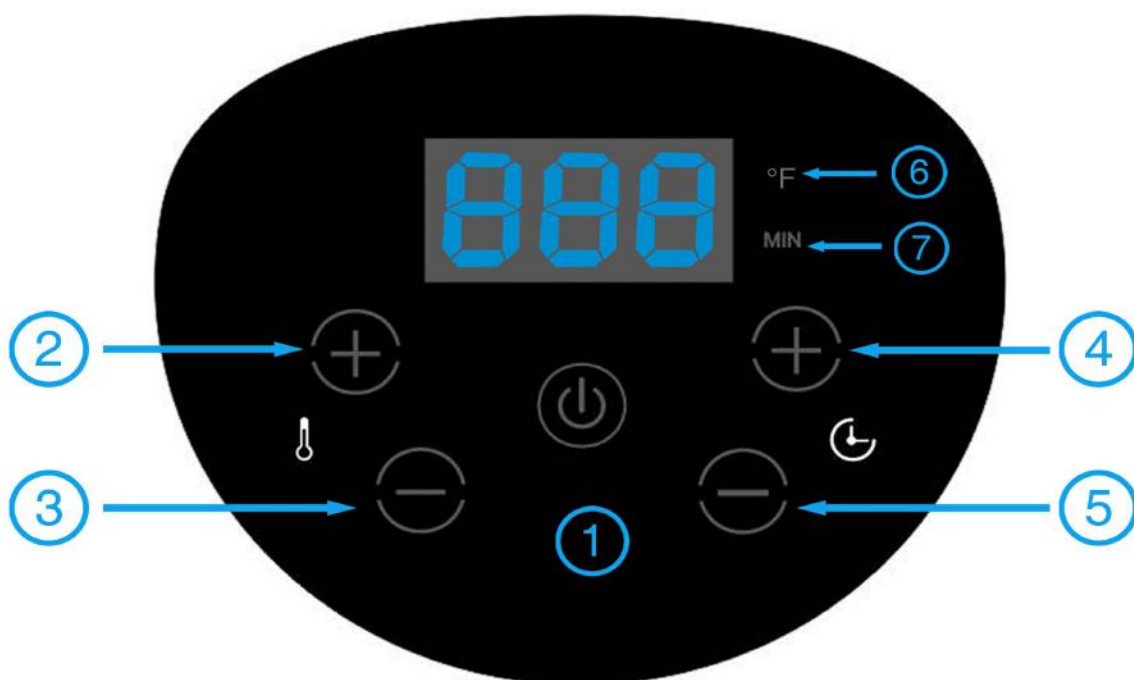

Fig.8

Panel control instructions

Operate the control panel as follows: (Fig. 8)

Button 1 –Power Button

Once the pan and fry basket are properly placed, the Power Button will be illuminated. Pressing the power button for 3 seconds will turn on the unit to the default temperature 360°F, while the cooking time will be set to 15 minutes. Then pressing the Power Button a second time will start the cooking process. Press the power button for 3 seconds to turn off the entire device during cooking. All the lights go off and the fan stops working.

Note: During cooking, you can touch the button to control the pause and start of cooking.

Button 2&3 –Temperature Control Buttons

The “+” and “-” symbols enable you to increase or decrease the cooking temperature 10°F at a time. Keep pressing the button, and you can rapidly change the temperature. Temperature Control range: 170°F-400°F.

Button 4&5 –Timer Control Buttons

The “+” and “-” symbols enable you to increase or decrease the cooking time, one minute at a time. Keep pressing the button, and you can rapidly change the time.

Indicator light 6

When this light is on, the panel displays temperature.

Indicator light 7

When this light is on, the panel displays time.

Settings

This table below will help you to select the basic settings for the ingredients.

Note: Keep in mind that these settings are indications. As ingredients differ in origin, size, shape as well as brand, we cannot guarantee the best setting for your ingredients.

Because the rapid air technology instantly reheats the air inside the appliance, pulling the pan briefly out of the appliance during hot air frying barely disturbs the process.

Tips:

- *A large amount of ingredients only requires a slightly longer preparation time, a smaller amount of ingredients only requires a slightly shorter preparation time.*
- *Shaking smaller ingredients halfway through the preparation time optimizes the frying and can help prevent unevenly fried ingredients.*
- *Add some oil to fresh potatoes for a crispy result. Fry your ingredients in the air fryer within a few minutes after you added the oil.*
- *Do not prepare extremely greasy ingredients such as sausages in the air fryer.*
- *Snacks that can be prepared in an oven can also be prepared in the air fryer.*
- *The optimal amount for preparing crispy fries is 500 grams.*
- *Use premade dough to prepare filled snacks quickly and easily. Premade dough also requires a shorter preparation time than homemade dough.*
- *Place a baking tin or oven dish in the air fryer basket if you want to bake a cake or quiche or if you want to fry fragile ingredients or filled ingredients*
- *You can also use the air fryer to reheat ingredients. To reheat ingredients, set the temperature to 300 °F for up to 10 minutes.*

	Min-max Amount (g)	Time (min.)	Temperature (°F)	Shake	Extra information
Potato & fries					
Thin frozen fries	300-400	15-20	400	shake	
Thick frozen fries	300-400	20-25	400	shake	
Potato gratin	500	20-25	390	shake	
Meat & Poultry					
Steak	100-500	15-20	360		
Pork chops	100-500	15-20	360		
Hamburger	100-500	15-20	360		
Sausage roll	100-500	13-15	390		
Drumsticks	100-500	15-22	400		
Chicken breast	100-500	15-20	360		
Snacks					
Spring rolls	100-400	8-10	390	shake	Use oven-ready food
Frozen chicken nuggets	100-500	10-15	390	shake	Use oven-ready food
Frozen fish fingers	100-400	15-20	400		Use oven-ready food
Frozen bread crumbed cheese snacks	100-400	8-10	360		Use oven-ready food
Stuffed vegetables	100-400	10-15	320		
Baking					
Cake	300	10-15	360		Use baking tin
Quiche	400	20-22	360		Use baking tin/oven dish
Muffins	300	15-18	390		Use baking tin
Sweet snacks	400	20	360		Use baking tin/oven dish

Note: Add 3 minutes to the preparation time when you start frying while the air fryer is still cold.

Cleaning

The pan and the non-stick coated basket:

Note: Clean the appliance after every use.

Do not use metal kitchen utensils or abrasive cleaning materials to clean them, as they may damage the non-stick coating.

1. Remove the mains plug from the wall socket and let the appliance cool down.

Note: Pull the pan out to let the hot air fryer cool down more quickly.

2. Wipe the outside of the appliance with moist cloth.
3. Clean the pan and basket with hot water, some dish washing liquid and a non-abrasive sponge.

You can use degreasing liquid to remove any remaining dirt.

Note: The pan and basket are dishwasher-safe.

Tip: If dirt is stuck to the basket or the bottom of the pan, fill the pan with hot water with some dish washing liquid. Put the basket in the pan and let the pan and the basket soak for approximately 10 minutes.

4. Clean the inside of the appliance with hot water and non-abrasive sponge.

5. Clean the heating elements with a cleaning brush to remove any food residues.

Storage

1 Unplug the appliance and let it cool down.

2 Make sure all parts are clean and dry.

Environment

Do not throw away the appliance with the common household wastes when it is exhausted, but take it to an official collection point for recycling. By doing this, you help to protect the environment.

Troubleshooting

Problem	Possible cause	Solution
The air fryer does not work.	The appliance is not plugged in.	Put the mains plug in polarized outlet.
	You have not set the timer.	Press the timer to the required preparation time to switch on the appliance.
The ingredients fried with the air fryer are not done.	The amount of ingredients in the basket is too much, or the size is too big.	Put smaller batches of ingredients in the basket. Smaller batches are fried more evenly.
	The set temperature is too low.	Press the temperature control button to the required temperature setting (see section 'settings' in chapter 'Using the appliance').
	The preparation time is too short.	Press the timer to the required preparation time (see section 'Settings' in chapter 'Using the appliance').
The ingredients are fried unevenly in the air fryer.	Certain types of ingredients need to be shaken halfway through the preparation time.	Ingredients that lie on top of or across each other (e.g. fries) need to be shaken halfway through the preparation time. See section 'Settings' in chapter 'Using the appliance'.
Fried snacks are not crispy when they come out of the air fryer.	The type of snacks used is meant to be prepared in a traditional deep fryer.	Use oven snacks or lightly brush some oil onto the snacks for a crispier result.
	The basket is not placed in the pan correctly.	Push the basket down into the pan until you hear a click.
White smoke comes out of the appliance.	You are preparing greasy ingredients.	When you fry greasy ingredients in the air fryer, a large amount of oil will leak into the pan. The oil produces white smoke and the pan may heat up more than usual. This does not affect the appliance or the cooking result.
	The pan still contains grease residues from previous use.	White smoke is caused by grease heating up in the pan. Make sure you clean the pan properly after each use.
Fresh fries are fried unevenly in the air fryer.	You did not use the right type of potato.	Use fresh potatoes and make sure they stay firm during frying.
	You did not rinse the potato sticks properly before you fried them.	Rinse the potato sticks in water properly to remove starch from the outside of the sticks.
Fresh fries are not crispy when they come out of the air fryer.	The crispiness of the fries depends on the amount of oil and water in the fries.	Make sure you dry the potato sticks properly before you add the oil.
		Cut the potato sticks smaller for a crispier result.
		Add slightly more oil for a crispier result.

Guarantee and service

We provide 30-day no-hassle return & refund guarantee, and worry-free 12-month warranty, starting from the date on which the appliance is sold to our customer.

The warranty only covers defects in material or workmanship.

The repairs under warranty may only be carried out by an authorized service center. When making a claim under the warranty, the original bill of purchase (with purchase date) must be submitted.

The warranty will not apply in cases of:

- Normal wear and tear
- Incorrect use, e.g. overloading of the appliance, use of non-approved accessories
- Use of force, damage caused by external influences
- Damage caused by non-observance of the user manual, e.g. connection to an unsuitable mains supply or non-compliance with the installation instructions
- Partially or completely dismantled appliances

HOLSEM

Your Safe is Our Priority

Add: 1045 E. Valley Blvd. A112, San Gabriel, CA 91776, United States

Email: customerservice@holsem.com