



for

LED



GooLED

GooLED-GE-8630 Pin Fin LED Heat Sink  $\Phi$ 86mm for GE Lighting

Features VS Benefits

- \* The GooLED-GE-8630 GE Lighting Pin Fin LED Heat Sinks are specifically designed for luminaires using the GE Lighting LED engines.
- \* Mechanical compatibility with direct mounting of the LED engines to the LED cooler and thermal performance matching the lumen packages.
- \* For spotlight and downlight designs from 800 to 2,100 lumen.
- \* Thermal resistance range Rth 2.86°C/W.
- \* Modular design with mounting holes foreseen for direct mounting of GE lighting Infusion™ LED engines.
- \* Diameter 86.5mm - standard height 30mm Other heights on request.
- \* Forged from highly conductive aluminum.



Zhaga LED engine and radiator assembly is a unified future international standardization

- \* Below you find an overview of GE Lighting engines COB's and LED modules which standard fit on the Pin Fin LED Heat Sinks.
- \* In this way mechanical after work and related costs can be avoided, and lighting designers can standardize their designs on a limited number of LED Pin Fin LED Heat Sink.

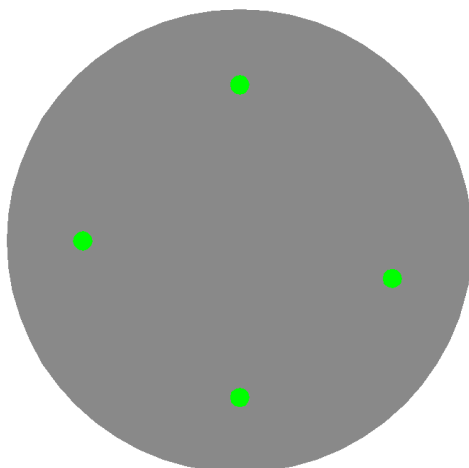

GE lighting LED engines for which Zhaga book5 LED Modules holders are available.

For the GE lighting Infusion™ M LED modules.

Infusion™ M3000

- M3000/827/W/G4;
- M3000/830/W/G4;
- M3000/835/W/G4;
- M3000/840/W/G4;
- M3000/930/W/G4;

Infusion™ M4500

- M4500/827/W/G4;
- M4500/830/W/G4;
- M4500/835/W/G4;
- M4500/840/W/G4;
- M4500/930/W/G4;

For the GE lighting Infusion™ DLM LED modules.

Infusion™ DLMM3000

- DLM3000/927;
- DLM3000/930;
- DLM3000/935;
- DLM3000/940;

Infusion™ DLM4000

- DLM4000/927;
- DLM4000/930;
- DLM4000/935;
- DLM4000/940;

Please refer to the "http://www.gelighting.com/LightingWeb/emea/" data provided on the manual.

Zhaga Book5 Green indicator marks:  
Direct mounting with machine screws M3.5x6.5mm;





for

LED



*GooLED*

**GooLED-GE-8630 Pin Fin LED Heat Sink  $\Phi$ 86mm for GE Lighting**

**Mounting Options and Drawings & Dimensions**

Example:GooLED-GE-8630-B-1

Example:GooLED-GE-86 **1** - **2** - **3**

**1** Height (mm)

**2** Anodising Color

B-Black

C-Clear

Z-Custom

**3** Mounting Options - see graphics for details Combinations available

Ex.order code - 12

means option 1 and 2 combined



GE Lighting

**Notes:**

- Mentioned models are an extraction of full product range.
- For specific mechanical adaptations please contact MingfaTech.
- MingfaTech reserves the right to change products or specifications without prior notice.

MOUNTING OPTION	Module type	Holder NO.	THREAD	THREAD DEPTH	THREAD HOLE DISTANCE
1	Infusion™ M Infusion™ DLM	GE Lighting	M3.5	6.5mm	$\Phi$ 58.4mm/ 4-M3.5 (Zhaga book5)

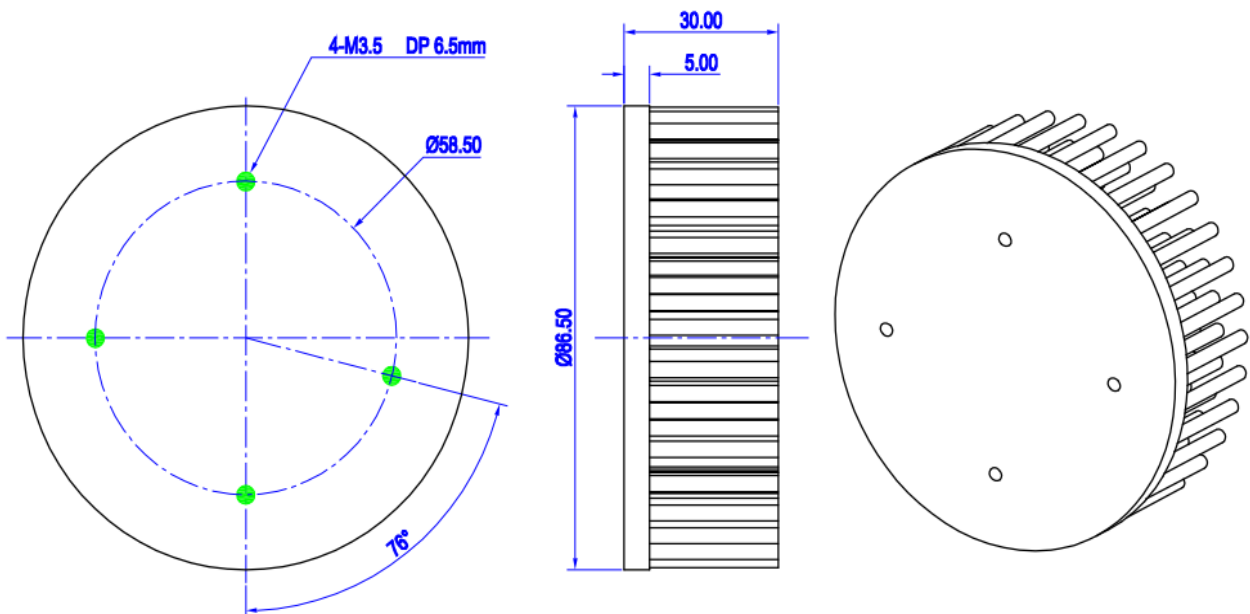



for

LED



GooLED

GooLED-GE-8630 Pin Fin LED Heat Sink Φ86mm for GE Lighting

The product data table

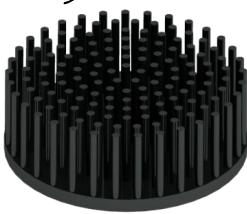
	Model No.	GooLED-GE-8630
	Heatsink Size	Φ86.5xH30mm
	Heatsink Material	AL1070
	Finish	Black Anodized
	Weight (g)	152.0
	Dissipated power (T <sub>hs-amb</sub> ,40°C)	14.0(W)
	Cooling surface area (mm <sup>2</sup> )	48926
	Thermal Resistance (R <sub>hs-amb</sub> )	2.86 (°C/W)

The thermal data table

\* Please be aware the dissipated power Pd is not the same as the electrical power Pe of a LED module.

\*To calculate the dissipated power please use the following formula: Pd = Pe x (1-ηL).

Pd - Dissipated power ; Pe - Electrical power ; ηL = Light efficiency of the LED module;

Dissipated Power Pd(W)	Heat sink to ambient thermal resistance R <sub>hs-amb</sub> (°C/W)		Heat sink to ambient temperature rise T <sub>hs-amb</sub> (°C)	
	GooLED-GE-8630			
6.0	4.00	24.0		
12.0	2.92	35.0		
18.0	2.56	46.0		
24.0	2.29	55.0		
32.0	1.88	60.0		

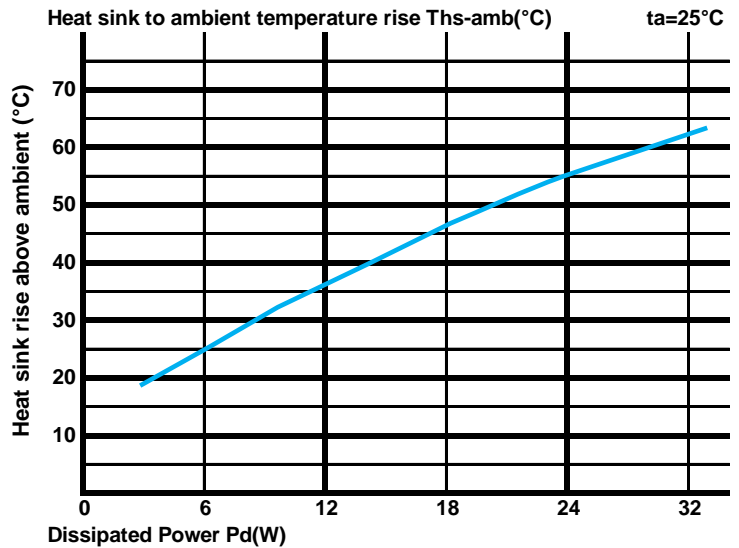

\*The aluminum substrate side of the package outer shell is thermally connected to the heat sink via TIM (Thermal interface material).

MingFa recommends the use of a high thermal conductive interface between the LED module and the LED cooler.

Either thermal grease, A thermal pad or a phase change thermal pad thickness 0.1-0.15mm is recommended.

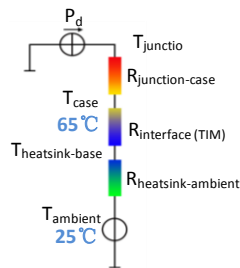

\*Thermal resistance is a heat property and a measurement of a temperature difference by which an object or material resists a heat flow.

Geometric shapes are different, the thermal resistance is different. Formula:  $\theta = (T_{hs} - T_a) / P_d$

$\theta$  - Thermal Resistance [°C/W]; T<sub>hs</sub> - Heatsink temperature; T<sub>a</sub> - Ambient temperature

\*The thermal resistance between the junction section of the light-emitting diode and the aluminum substrate side of the package outer shell is R<sub>junction-case</sub>, the thermal resistance of the TIM outside the package is R<sub>interface (TIM)</sub> [°C/W], the thermal resistance with the heat sink is R<sub>heatsink-ambient</sub> [°C/W], and the ambient temperature is T<sub>ambient</sub> [°C].

\*Thermal resistances outside the package R<sub>interface (TIM)</sub> and R<sub>heatsink-ambient</sub> can be integrated into the thermal resistance R<sub>case-ambient</sub> at this point. Thus, the following formula is also used:

$$T_{junction} = (R_{junction-case} + R_{case-ambient}) \cdot P_d + T_{ambient}$$

