



xLED

xLED-LUM-6050 Pin Fin Heat Sink Φ 60mm for LumiLEDs

Features VS Benefits

- * The xLED-LUM-6050 LumiLEDs Pin Fin LED Heat Sinks are specifically designed for luminaires using the LumiLEDs LED engines.
- * Mechanical compatibility with direct mounting of the LED engines to the LED cooler and thermal performance matching the lumen packages.
- * For spotlight and downlight designs from 900 to 2,200 lumen.
- * Thermal resistance range R_{th} 3.85°C/W.
- * Modular design with mounting holes foreseen for direct mounting of LumiLEDs COB series.
- * Diameter 60mm - standard height 50mm, Other heights on request.
- * Forged from highly conductive aluminum.



Zhaga LED engine and radiator assembly is a unified future international standardization

- * Below you find an overview of LumiLEDs COB's and LED modules which standard fit on the Pin Fin LED Heat Sinks.
- * In this way mechanical after work and related costs can be avoided, and lighting designers can standardize their designs on a limited number of LED Pin Fin LED Heat Sink.

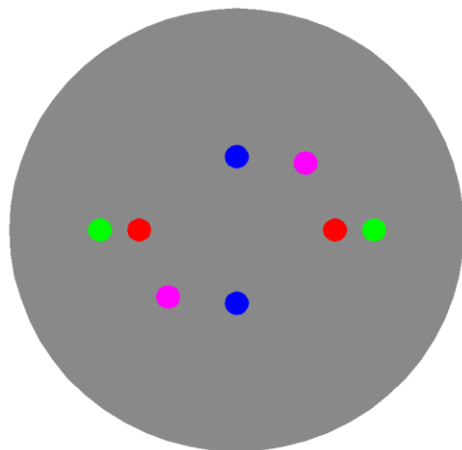

LumiLEDs LED Modules directly Mounting Options

LumiLEDs COB series.

- LUXEON CoB 1202s: L2C5-xxxx1202E0600;
- LUXEON CoB 1202HD: L2C5-xxxx1202EH600;

With the Zhaga Book 11 holders for the red indicator marks.
TE Connectivity Holder: 2213118-2;
BJB Holder: 47.319.6180.50;
Without the holders for the blue indicator marks.
Direct mounting with machine screws M3x6.5mm.

LumiLEDs COB series.

- LUXEON CoB 1202: L2C5-xxxx1202E0900;
- LUXEON CoB 1203: L2C5-xxxx1203E0900;

With the Zhaga Book 3 holders for the green indicator marks.
TE Connectivity Holder: 2213382-1;
Without the holders for the pink indicator marks.
Direct mounting with machine screws M3x6.5mm.

LuXEon CX Plus CoB series.

- LUXEON CoB M02: L2C4-xxxx-M02E0900;
- LUXEON CoB M03: L2C4-xxxx-M03E0900;

With the Zhaga Book 11 holders for the red indicator marks.
BJB Holder: 47.319.6104.50;
Direct mounting with machine screws M3x6.5mm.

With the LEDiL products:
Ronda series: FN15xxx-xx;

xLED

xLED-LUM-6050 Pin Fin Heat Sink Φ 60mm for LumiLEDs

Mounting Options and Drawings & Dimensions

Example: xLED-LUM-6050-B-1,2

Example: xLED-LUM-60 **1** - **2** - **3**

- 1** Height (mm)
- 2** Anodising Color
 - B-Black
 - C-Clear
 - Z-Custom
- 3** Mounting Options - see graphics for details Combinations available
Ex.order code - 12
means option 1 and 2 combined

Notes:

- Mentioned models are an extraction of full product range.
- For specific mechanical adaptations please contact MingfaTech.
- MingfaTech reserves the right to change products or specifications without prior notice.

MOUNTING OPTION	Module type	Holder NO.	LEDiL products		THREAD	THREAD DEPTH	THREAD HOLE DISTANCE
			Ronda series	Olivia series			
1	LUXEON 1202s; LUXEON 1202HD;	/	FN15xxx-xx;	/	M3	6.5mm	19.2mm/ 2-@180°
2	LUXEON CoB M02; LUXEON CoB M03;	BJB Holder 47.319.6104.50			M3	6.5mm	25.0mm/ 2-@180°
	LUXEON 1202s; LUXEON 1202HD;	BJB Holder 47.319.6180.50 TE Holder 2213118-2					
3	LUXEON 1202; LUXEON 1203;	/			M3	6.5mm	24.8mm/ 2-@180°
4		TE Holder 2213382-1	M3	6.5mm	35.0mm/ 2-@180° (Zhaga Book 3)		

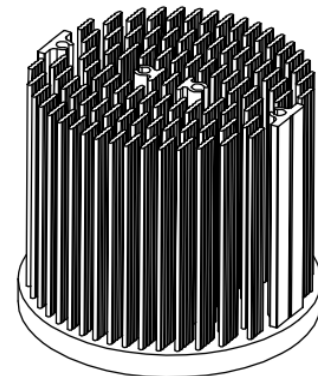
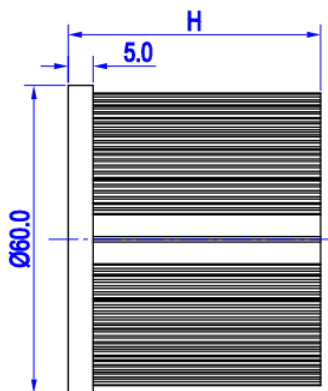
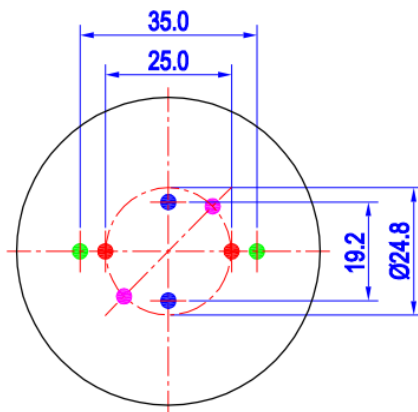

xLED

xLED-LUM-6050 Pin Fin Heat Sink $\Phi 60\text{mm}$ for LumiLEDs

The product data table

	Model No.	xLED-LUM-6050
	Heatsink Size	$\Phi 60 \times H 50\text{mm}$
	Heatsink Material	AL1070
	Finish	Black Anodized
	Weight (g)	112.0
	Dissipated power (T _{hs-amb} , 50°C)	13.0 (W)
	Cooling surface area (mm ²)	68473
	Thermal Resistance (R _{hs-amb})	3.85 (°C/W)

The thermal data table

* Please be aware the dissipated power Pd is not the same as the electrical power Pe of a LED module.

* To calculate the dissipated power please use the following formula: $P_d = P_e \times (1 - \eta_L)$.

Pd - Dissipated power ; Pe - Electrical power ; η_L = Light efficiency of the LED module;

Dissipated Power Pd(W)	Pd = Pe x (1- η_L)	Heat sink to ambient thermal resistance R _{hs-amb} (°C/W)	Heat sink to ambient temperature rise T _{hs-amb} (°C)
		xLED-LUM-6050	
3.0		5.67	17.0
6.0		4.83	29.0
9.0		4.22	38.0
12.0		4.00	48.0
15.0		3.73	56.0

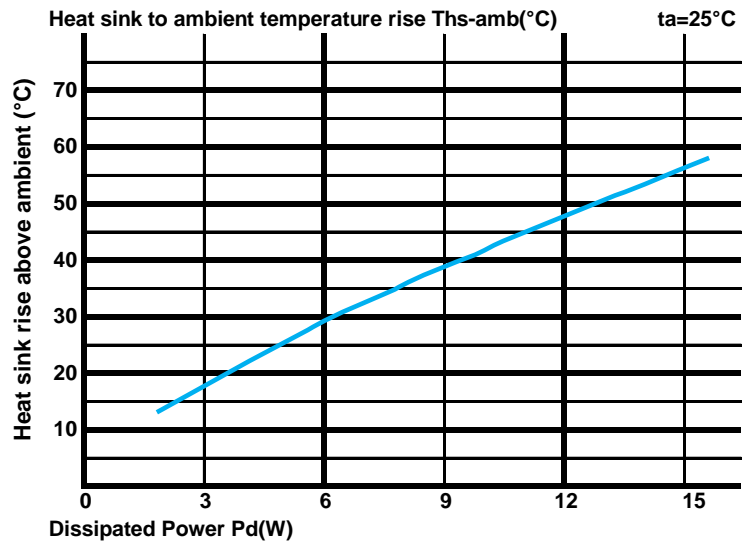

*The aluminum substrate side of the package outer shell is thermally connected to the heat sink via TIM (Thermal interface material).

MingFa recommends the use of a high thermal conductive interface between the LED module and the LED cooler.

Either thermal grease, A thermal pad or a phase change thermal pad thickness 0.1-0.15mm is recommended.

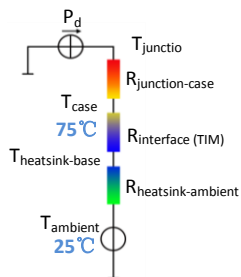

*Thermal resistance is a heat property and a measurement of a temperature difference by which an object or material resists a heat flow.

Geometric shapes are different, the thermal resistance is different. Formula: $\theta = (T_{hs} - T_a) / P_d$

θ - Thermal Resistance [°C/W] ; T_{hs} - Heatsink temperature ; T_a - Ambient temperature ;

*The thermal resistance between the junction section of the light-emitting diode and the aluminum substrate side of the package outer shell is R_{junction-case}, the thermal resistance of the TIM outside the package is R_{interface (TIM)} [°C/W], the thermal resistance with the heat sink is R_{heatsink-ambient} [°C/W], and the ambient temperature is T_{ambient} [°C].

*Thermal resistances outside the package R_{interface (TIM)} and R_{heatsink-ambient} can be integrated into the thermal resistance R_{case-ambient} at this point. Thus, the following formula is also used:

$$T_{\text{junction}} = (R_{\text{junction-case}} + R_{\text{case-ambient}}) \cdot P_d + T_{\text{ambient}}$$