



for

LED



GooLED

GooLED-TRI-7830 Pin Fin Heat Sink Φ 78mm for Tridonic

Features VS Benefits

- * The GooLED-TRI-7830 Tridonic Pin Fin LED Heat Sinks are specifically designed for luminaires using the Tridonic LED engines.
- * Mechanical compatibility with direct mounting of the LED engines to the LED cooler and thermal performance matching the lumen packages.
- * For spotlight and downlight designs from 1,000 to 2,700 lumen.
- * Thermal resistance range R_{th} 3.03°C/W.
- * Modular design with mounting holes foreseen for direct mounting of Tridonic SLE series modules.
- * Diameter 78.0mm - standard height 30.0mm, Other heights on request.
- * Forged from highly conductive aluminum.



Zhaga LED engine and radiator assembly is a unified future international standardization

- * Below you find an overview of Tridonic COB's and LED modules which standard fit on the Pin Fin LED Heat Sinks.
- * In this way mechanical after work and related costs can be avoided, and lighting designers can standardize their designs on a limited number of LED Pin Fin LED Heat Sink.



Tridonic LED Modules directly Mounting Options.

Modules SLE EXCITE, FOOD, ART, FASHION Series.
Modules SLE ADVANCED, G6 ADV Series.

SLE G6 19mm 5000lm-xxx; | SLE G6 23mm 6000lm-xxx;

With the Zhaga Book 3 holders for the green indicator marks.
Direct mounting with machine screws M3x6.5mm.

Modules SLE EXCITE, FASHION, TINGE series.
Modules SLE ADVANCED, G5 XD ADV and G6 ADV Series.
Modules SLE ESSENCE, G6 SNC Series.

SLE G6 15mm 3000lm-xxx; | SLE G6 17mm 4000lm-xxx;

With the Zhaga Book 3 holders for the green indicator marks.
BJB holder: 47.319.2021.50; AAG.STUCCHI: 8101-G2
Without the holders for the red indicator marks.
Direct mounting with machine screws M3x6.5mm.

With the LEDiL products:
Olivia series: FN14637-S; FN14828-M;
Ronda series: FN15xxx-xx;

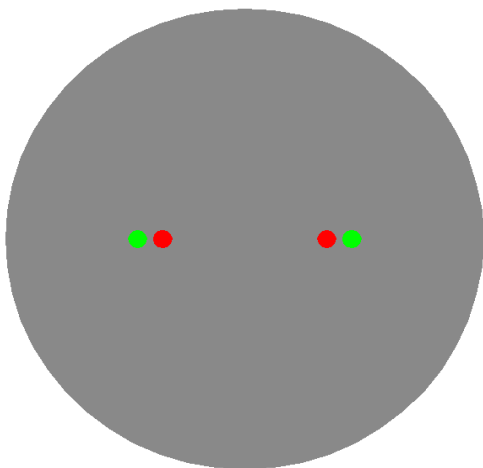

GooLED

GooLED-TRI-7830 Pin Fin Heat Sink Φ 78mm for Tridonic

Mounting Options and Drawings & Dimensions

Example:GooLED-TRI-7830-B-1,2

Example:GooLED-TRI-78 **1** - **2** - **3**

- 1** Height (mm)
- 2** Anodising Color
B-Black
C-Clear
Z-Custom
- 3** Mounting Options - see graphics for details Combinations available
Ex.order code - 12
means option 1 and 2 combined

Notes:

- Mentioned models are an extraction of full product range.
- For specific mechanical adaptations please contact MingfaTech.
- MingfaTech reserves the right to change products or specifications without prior notice.

MOUNTING OPTION	Module type	Holder NO.	LEDiL products		THREAD	THREAD DEPTH	THREAD HOLE DISTANCE
			Olivia Series	Ronda series			
1		/			M3	6.5mm	26.8mm/ 2-@180°
2	SLE G6 15mm; SLE G6 17mm;	BJB Holder 47.319.2021.50	FN14637-S; FN14828-M;	FN15xxx-xx;	M3	6.5mm	35.0mm/ 2-@180° (Zhaga book 3)
		AAG.STUCCHI 8101-G2					
	SLE G6 19mm; SLE G6 23mm;	/	/	/			

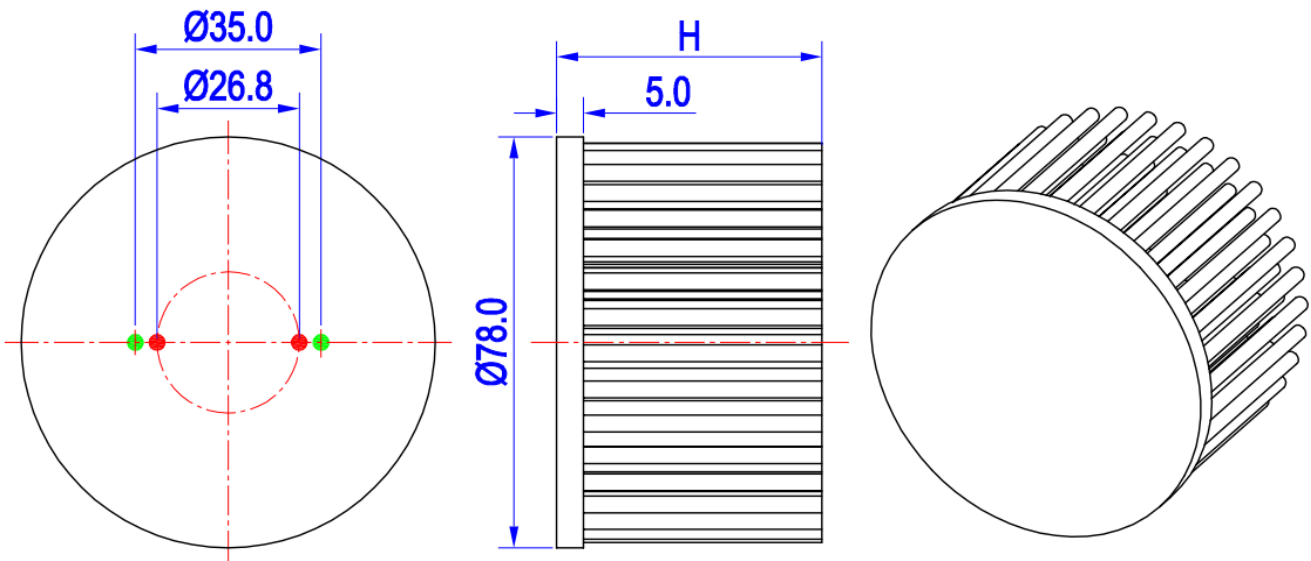

GooLED

GooLED-TRI-7830 Pin Fin Heat Sink $\Phi 78\text{mm}$ for Tridonic

The product data table

	Model No.	GooLED-TRI-7830
	Heatsink Size	$\Phi 78 \times H 30\text{mm}$
	Heatsink Material	AL1070
	Finish	Black Anodized
	Weight (g)	138.0
	Dissipated power (T_{hs-amb}, 50°C)	16.5 (W)
	Cooling surface area (mm²)	46643
	Thermal Resistance (R_{hs-amb})	3.03 (°C/W)

The thermal data table

* Please be aware the dissipated power Pd is not the same as the electrical power Pe of a LED module.

* To calculate the dissipated power please use the following formula: $P_d = P_e \times (1 - \eta_L)$.

Pd - Dissipated power ; Pe - Electrical power ; η_L = Light efficiency of the LED module;

Dissipated Power Pd(W)	Pd = Pe x (1- η_L)	Heat sink to ambient thermal resistance R _{hs-amb} (°C/W)	Heat sink to ambient temperature rise T _{hs-amb} (°C)
		GooLED-TRI-7830	
5.0		4.80	24.0
10.0		3.60	36.0
15.0		3.13	47.0
20.0		2.95	59.0
25.0		2.72	68.0

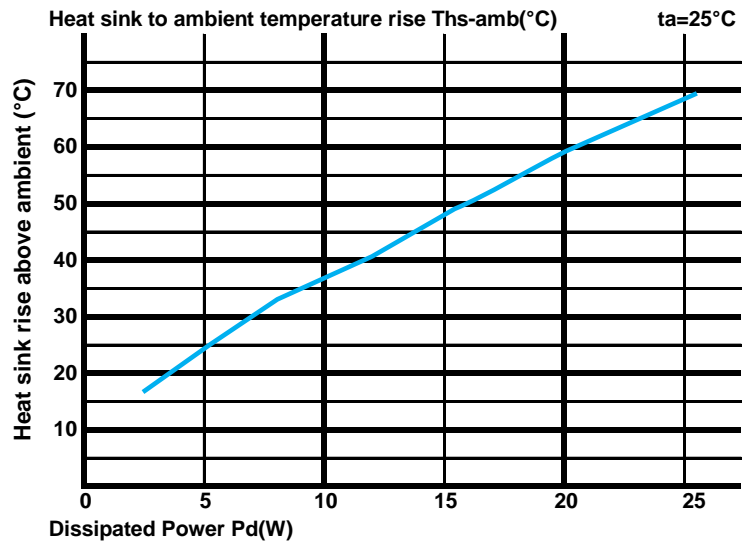

*The aluminum substrate side of the package outer shell is thermally connected to the heat sink via TIM (Thermal interface material).

MingFa recommends the use of a high thermal conductive interface between the LED module and the LED cooler.

Either thermal grease, A thermal pad or a phase change thermal pad thickness 0.1-0.15mm is recommended.



*Thermal resistance is a heat property and a measurement of a temperature difference by which an object or material resists a heat flow.

Geometric shapes are different, the thermal resistance is different. Formula: $\theta = (T_{hs} - T_a) / P_d$

θ - Thermal Resistance [°C/W] ; T_{hs} - Heatsink temperature ; T_a - Ambient temperature ;

*The thermal resistance between the junction section of the light-emitting diode and the aluminum substrate side of the package outer shell is R_{junction-case}, the thermal resistance of the TIM outside the package is R_{interface (TIM)} [°C/W], the thermal resistance with the heat sink is R_{heatsink-ambient} [°C/W], and the ambient temperature is T_{ambient} [°C].

*Thermal resistances outside the package R_{interface (TIM)} and R_{heatsink-ambient} can be integrated into the thermal resistance R_{case-ambient} at this point. Thus, the following formula is also used:

$$T_{\text{junction}} = (R_{\text{junction-case}} + R_{\text{case-ambient}}) \cdot P_d + T_{\text{ambient}}$$